

89-500 SERIES

Carbon Steel Ball Valve With Spring Return Handle

Female NPT Thread, 1/4" to 1" 2000 CWP (psig), 1.25" to 2" 1500 CWP (psig). Cold Non-Shock.
 150 psig Saturated Steam.
 Vacuum Service to 29 inches Hg.
 MSS SP-110 compliant.



FEATURES

- Spring return to close ("01" suffix)
- Spring return to open ("08" suffix)
- All components of lever are stainless steel
- Zinc phosphate corrosion protection
- Operating torque is approximately three times standard valve torque

- Blow-out-proof stem design
- Adjustable packing gland
- Investment cast components
- Multifill seats

VARIATIONS AVAILABLE:

89-540 Series (316 SS Ball & Stem)

OPTIONS AVAILABLE: (More information in Section J)

| (SUFFIX) | OPTION | SIZES |
|----------|------------------------------------|------------|
| -01 | Standard Configuration | All |
| -P -01- | BSPP (Parallel) Thread Connection | 1/4" to 2" |
| -T -01- | BSPT (Tapered) Thread Connection | 1/4" to 2" |
| -08- | 90° Reversed Stem | 1/4" to 2" |
| -14- | Side Vented Ball (Uni-Directional) | 1/4" to 2" |
| -24- | Graphite Packing | 1/4" to 2" |
| -35- | PTFE Trim | 1/4" to 2" |

STANDARD MATERIAL LIST

| PART | MATERIAL |
|----------------|--|
| 1 Handle | SS |
| 2 Stem packing | Multifill PTFE |
| 3 Stem bearing | RPTFE |
| 4 Ball | A108-CS chrome plated |
| 5 Seat (2) | Multifill PTFE |
| 6 Retainer | A108-CS (1/4" to 1") A216-WCB (1.25" to 2") |
| 7 Gland nut | A108-CS |
| 8 Stem | A276-316 |
| 9 Lever nut | Steel, Zinc Plated |
| 10 Body seal | PTFE (1.25" to 2") |
| 11 Body | A216-WCB |

| PRODUCT NUMBER | SIZE | A | B | C | D | WT. |
|----------------|-------|------|------|------|------|------|
| 89-501-01A | 1/4" | 0.37 | 1.03 | 2.06 | 7.00 | 1.26 |
| 89-502-01A | 3/8" | 0.37 | 1.03 | 2.06 | 7.00 | 1.25 |
| 89-503-01A | 1/2" | 0.50 | 1.12 | 2.25 | 7.00 | 1.31 |
| 89-504-01A | 3/4" | 0.68 | 1.50 | 3.00 | 7.00 | 1.98 |
| 89-505-01A | 1" | 0.87 | 1.68 | 3.37 | 7.00 | 2.35 |
| 89-506-01 | 1.25" | 1.00 | 2.00 | 4.00 | 9.00 | 3.96 |
| 89-507-01 | 1.5" | 1.25 | 2.18 | 4.37 | 9.00 | 4.78 |
| 89-508-01 | 2" | 1.50 | 2.75 | 5.50 | 9.00 | 6.66 |

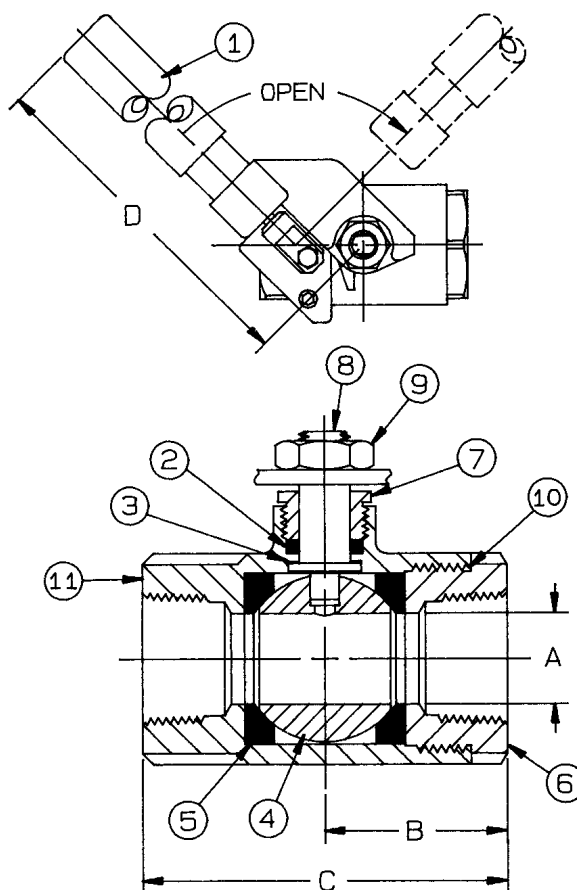

FOR PRESSURE/TEMPERATURE RATINGS, REFER TO PAGE M-14, GRAPH NO. 13
 (1/4" TO 1") REFER TO PAGE M-13 GRAPH NO. 11 (1.25" TO 2")

FLOW DATA

For Apollo® Ball Valves

The listed Cv "factors" are derived from actual flow testing, in the Apollo® Ball Valve Division, Conbraco Industries, Inc., Pageland, South Carolina. These tests were completed using standard "off the shelf" valves with no special preparation and utilizing standard schedule 40 pipe. It should be understood that these factors are for the valve only and also include the connection configuration. The flow testing is done utilizing water as a fluid media and is a direct statement of the gallons of water flowed per minute with a 1 psig pressure differential across the valve/connection unit. Line pressure is not a factor. Because the Cv is a factor, the formula can be used to estimate flow of most media for valve sizing.

FLOW OF LIQUID

$$Q = C_v \sqrt{\frac{\Delta P}{SpGr}}$$

$$\text{or } \Delta P = \frac{(Q)^2 (SpGr)}{(Cv)^2}$$

Where:

Q = flow in US gpm
 ΔP = pressure drop (psig)
 SpGr = specific gravity at flowing temperature
 Cv = valve constant

FLOW OF GAS

$$Q = 1360 C_v \sqrt{\frac{(\Delta P) (P_2)}{(SpGr) (T)}}$$

$$\text{or } \Delta P = \frac{5.4 \times 10^{-7} (SpGr) (T) (Q)^2}{(Cv)^2 (P_2)}$$

Where:

Q = flow in SCFH
 ΔP = pressure drop (psig)
 SpGr = specific gravity (based on air = 1.0)
 P₂ = outlet pressure-psia (psig + 14.7)
 T = (temp. °F + 460)
 Cv = valve constant

Cv FACTORS FOR APOLLO VALVES

| SIZE (IN.) | 1/4 | 3/8 | 1/2 | 3/4 | 1 | 1.25 | 1.5 | 2 | 2.5 | 3 | 4 | 6 | 8 | 10 | 12 |
|--------------------|-----|-----|-----|-----|----|------|-----|-----|-----|------|------|----|----|----|----|
| VALVE | | | | | | | | | | | | | | | |
| 32-100/200 Series | 5.1 | 6.6 | 8 | 24 | 30 | 45 | 55 | 95 | -- | -- | -- | -- | -- | -- | -- |
| 64-100/200 Series | 6 | 7 | 19 | 34 | 50 | 104 | 268 | 309 | 629 | 1018 | 1622 | -- | -- | -- | -- |
| 64W Series | -- | -- | -- | -- | -- | -- | -- | -- | 629 | 1018 | 1622 | -- | -- | -- | -- |
| 70B-140 Series | 8.4 | 7.2 | 15 | 30 | 43 | 48 | 84 | 108 | 190 | 370 | 670 | -- | -- | -- | -- |
| 70-100/200 Series | 8.4 | 7.2 | 15 | 30 | 43 | 48 | 84 | 108 | 190 | 370 | 670 | -- | -- | -- | -- |
| 70-300/400 Series | -- | -- | 15 | 30 | 43 | 48 | 84 | 108 | -- | -- | -- | -- | -- | -- | -- |
| 70-600 Series | 2.3 | 4.5 | 5.4 | 12 | 14 | 21 | 34 | 47 | -- | -- | -- | -- | -- | -- | -- |
| 70-800 Series | 8.4 | 7.2 | 15 | 30 | 43 | 48 | 84 | -- | -- | -- | -- | -- | -- | -- | -- |
| 71AR Series | -- | -- | -- | 30 | 43 | 48 | 84 | 108 | 190 | 370 | -- | -- | -- | -- | -- |
| 71-100/200 Series | -- | -- | -- | 30 | 43 | 48 | 84 | 108 | 190 | 370 | -- | -- | -- | -- | -- |
| 72-100/900 Series | -- | -- | 26 | 48 | 65 | 125 | 170 | 216 | -- | -- | -- | -- | -- | -- | -- |
| 73A-100 Series | 8.4 | 7.2 | 15 | 30 | 43 | 48 | 84 | 108 | -- | -- | -- | -- | -- | -- | -- |
| 73-300/400 Series | -- | -- | 26 | 48 | 65 | 125 | 170 | 216 | -- | -- | -- | -- | -- | -- | -- |
| 74-100 Series | 8.4 | 7.2 | 15 | 30 | 43 | 48 | 84 | 108 | 190 | 370 | 670 | -- | -- | -- | -- |
| 75-100 Series | 8.4 | 7.2 | 15 | 30 | 43 | 48 | 84 | 108 | 190 | 370 | 670 | -- | -- | -- | -- |
| 76AR Series | 8.4 | 7.2 | 15 | 30 | 43 | 48 | 84 | 108 | 190 | 370 | 670 | -- | -- | -- | -- |
| 76F-100 Series | 8.1 | 15 | 15 | 51 | 68 | 125 | 177 | 389 | -- | -- | -- | -- | -- | -- | -- |
| 76-100 Series | 8.4 | 7.2 | 15 | 30 | 43 | 48 | 84 | 108 | 190 | 370 | -- | -- | -- | -- | -- |
| 76-300/400 Series | -- | -- | 26 | 48 | 65 | 125 | 170 | 216 | -- | -- | -- | -- | -- | -- | -- |
| 76-600 Series | 2.3 | 4.5 | 5.4 | 12 | 14 | 21 | 34 | 47 | -- | -- | -- | -- | -- | -- | -- |
| 7K-100 Series | -- | -- | 15 | 51 | 68 | 125 | 177 | 389 | 503 | -- | -- | -- | -- | -- | -- |
| 77AR Series | 8.1 | 15 | 15 | 51 | 68 | 125 | 177 | 389 | -- | -- | -- | -- | -- | -- | -- |
| 77C-100/200 Series | 4.5 | 7.2 | 16 | 36 | 68 | 125 | 177 | 389 | 503 | -- | -- | -- | -- | -- | -- |
| 77D-140 Series | 4.5 | 7.2 | 16 | 36 | 68 | 125 | 177 | 389 | -- | -- | -- | -- | -- | -- | -- |
| 77D-640 Series | -- | -- | -- | 11 | 24 | 35 | -- | -- | -- | -- | -- | -- | -- | -- | -- |
| 77G-UL Series | 4.5 | 7.2 | 16 | 36 | 68 | 125 | 177 | 389 | 503 | -- | -- | -- | -- | -- | -- |
| 77W Series | -- | -- | 16 | 36 | 68 | 125 | 177 | 389 | -- | -- | -- | -- | -- | -- | -- |
| 77X Series | -- | -- | 16 | 36 | 68 | -- | -- | -- | -- | -- | -- | -- | -- | -- | -- |
| 77-100/200 Series | 8.1 | 15 | 15 | 51 | 68 | 125 | 177 | 389 | 503 | -- | -- | -- | -- | -- | -- |
| 79 Series | 8.5 | 8.5 | 9.8 | 32 | 44 | 66 | 148 | 218 | 440 | 390 | -- | -- | -- | -- | -- |

continued on next page



FLOW DATA

For Apollo® Ball Valves

Cv FACTORS FOR APOLLO VALVES (continued from page M-3)

| SIZE (IN.) | 1/4 | 3/8 | 1/2 | 3/4 | 1 | 1.25 | 1.5 | 2 | 2.5 | 3 | 4 | 6 | 8 | 10 | 12 |
|--------------------|-----|-----|-----|-----|----|------|-----|-----|-----|------|------|------|------|-------|-------|
| VALVE | | | | | | | | | | | | | | | |
| 80/81 Series | 8.4 | 7.2 | 15 | 30 | 43 | 48 | 84 | 108 | 190 | 370 | -- | -- | -- | -- | -- |
| 82-100/200 Series | 8.1 | 14 | 26 | 51 | 68 | 120 | 170 | 376 | 510 | 996 | 1893 | -- | -- | -- | -- |
| 83A/83B Series | 8.1 | 14 | 26 | 51 | 68 | 120 | 170 | 376 | -- | -- | -- | -- | -- | -- | -- |
| 83R-100/200 Series | -- | -- | -- | -- | -- | -- | 170 | 376 | -- | 996 | 1893 | -- | -- | -- | -- |
| 86A/86B Series | 8.1 | 14 | 26 | 51 | 68 | 120 | 170 | 376 | -- | -- | -- | -- | -- | -- | -- |
| 86R-100/200 Series | -- | -- | -- | -- | -- | -- | 170 | 376 | -- | 996 | 1893 | -- | -- | -- | -- |
| 87A-100 Series | -- | -- | -- | -- | -- | -- | 86 | 104 | 234 | 375 | 673 | 1099 | 1902 | 3890 | -- |
| 87A-200 Series | -- | -- | 15 | 19 | 75 | -- | 195 | 410 | 545 | 1021 | 2016 | 4837 | 9250 | 15170 | 22390 |
| 87A-700 Series | -- | -- | -- | -- | -- | -- | 86 | 104 | 234 | 375 | 673 | 1099 | 1902 | 3890 | -- |
| 87A-900 Series | -- | -- | 15 | 19 | 75 | -- | 195 | 410 | 545 | 1021 | 2016 | 4837 | 9250 | 15170 | 22390 |
| 87B-100 Series | -- | -- | -- | -- | -- | -- | -- | -- | -- | 375 | 673 | 1099 | 1902 | 3890 | -- |
| 88A-100 Series | -- | -- | -- | -- | -- | -- | 86 | 104 | 234 | 375 | 673 | 1099 | 1902 | 3890 | -- |
| 88A-200 Series | -- | -- | 15 | 19 | 75 | -- | 195 | 410 | 545 | 1021 | 2016 | 4837 | 9250 | 15170 | 22390 |
| 88A-700 Series | -- | -- | -- | -- | -- | -- | 86 | 104 | 234 | 375 | 673 | 1099 | 1902 | 3890 | -- |
| 88A-900 Series | -- | -- | 15 | 19 | 75 | -- | 195 | 410 | 545 | 1021 | 2016 | 4837 | 9250 | 15170 | 22390 |
| 88B-100 Series | -- | -- | -- | -- | -- | -- | -- | -- | -- | 375 | 673 | 1099 | 1902 | 3890 | -- |
| 89-100 Series | 8.4 | 7.2 | 15 | 30 | 43 | 48 | 84 | 108 | 190 | 370 | -- | -- | -- | -- | -- |
| 9A-100 Series | 8.3 | 6.7 | 5.7 | 10 | 16 | 25 | 40 | 62 | -- | -- | -- | -- | -- | -- | -- |
| 91-100 Series | 8.3 | 6.7 | 5.7 | 10 | 16 | 25 | 40 | 62 | -- | -- | -- | -- | -- | -- | -- |
| 92-100 Series | 8.3 | 6.7 | 5.7 | 10 | 16 | 25 | 40 | 62 | -- | -- | -- | -- | -- | -- | -- |
| 93-100 Series | 8.3 | 6.7 | 5.7 | 10 | 16 | 25 | 40 | 62 | -- | -- | -- | -- | -- | -- | -- |
| 94A-100/200 Series | 6 | 7 | 19 | 34 | 50 | 104 | 268 | 309 | 629 | 1018 | 1622 | -- | -- | -- | -- |
| 95-100/200 Series | -- | -- | 15 | 51 | 68 | -- | -- | -- | -- | -- | -- | -- | -- | -- | -- |
| 95A-300/400 Series | -- | -- | 19 | 34 | 50 | -- | -- | -- | -- | -- | -- | -- | -- | -- | -- |
| 96-100 Series | 8.3 | 6.7 | 5.7 | 10 | 16 | 25 | 40 | 62 | -- | -- | -- | -- | -- | -- | -- |
| 399-100 Series | 8.4 | 7.2 | 15 | 30 | 43 | 48 | 84 | 108 | 190 | 370 | -- | -- | -- | -- | -- |
| 489-100 Series | 8.4 | 7.2 | 15 | 30 | 43 | 48 | 84 | 108 | 190 | 370 | -- | -- | -- | -- | -- |

PRESSURE TEMPERATURE RATINGS

2000# CS (GRAPH 13)

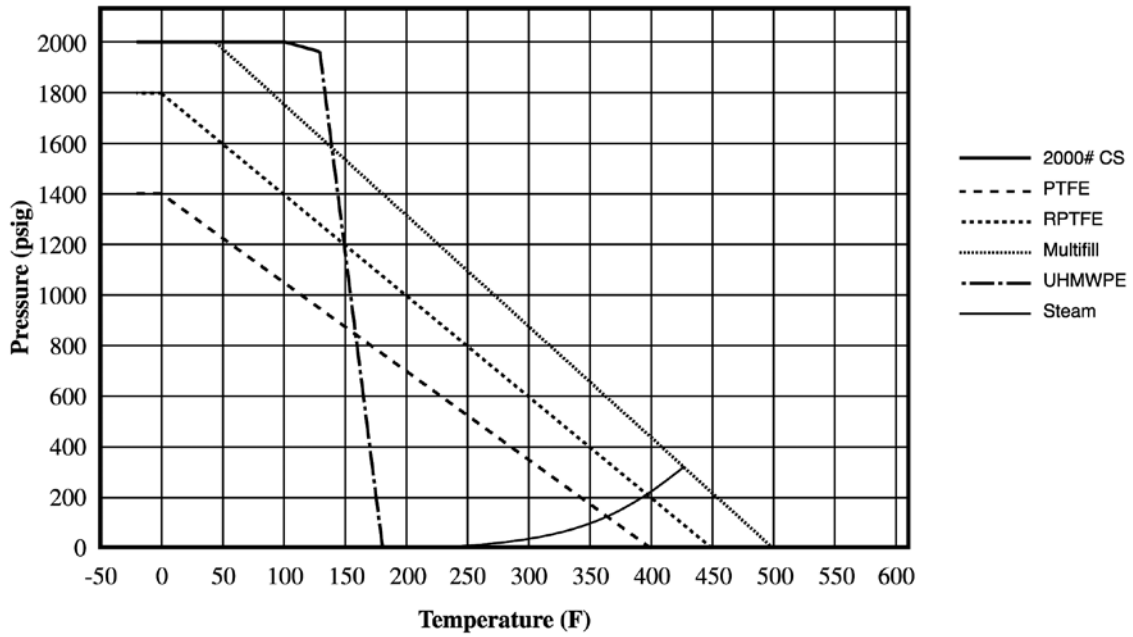

2000# SS (GRAPH 14)

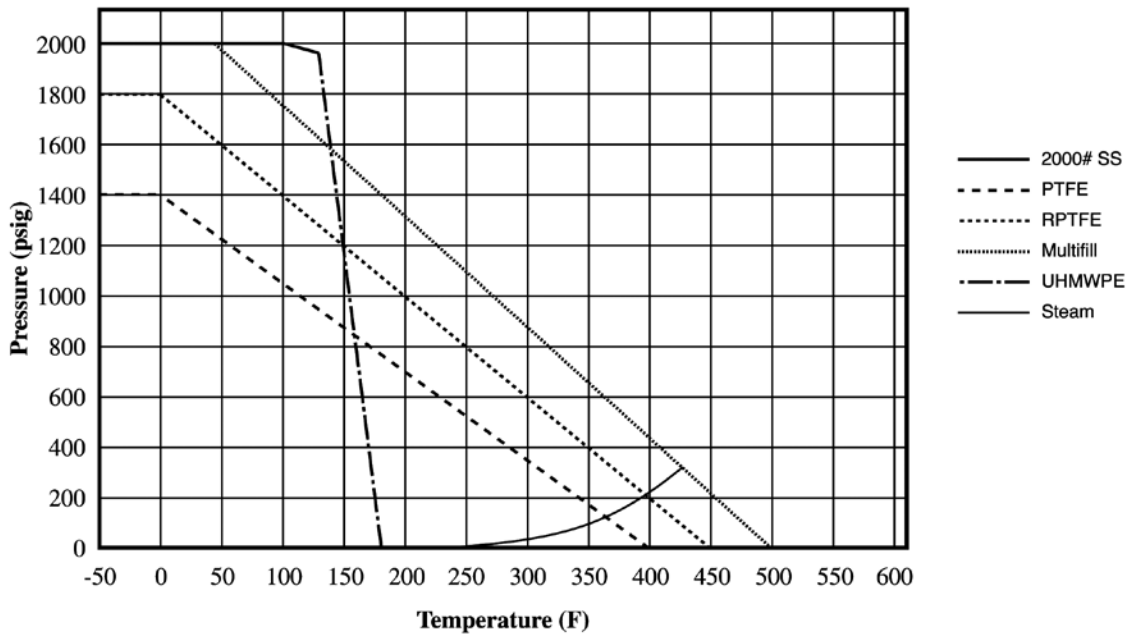

PRESSURE TEMPERATURE RATINGS

1500# CS (GRAPH 11)

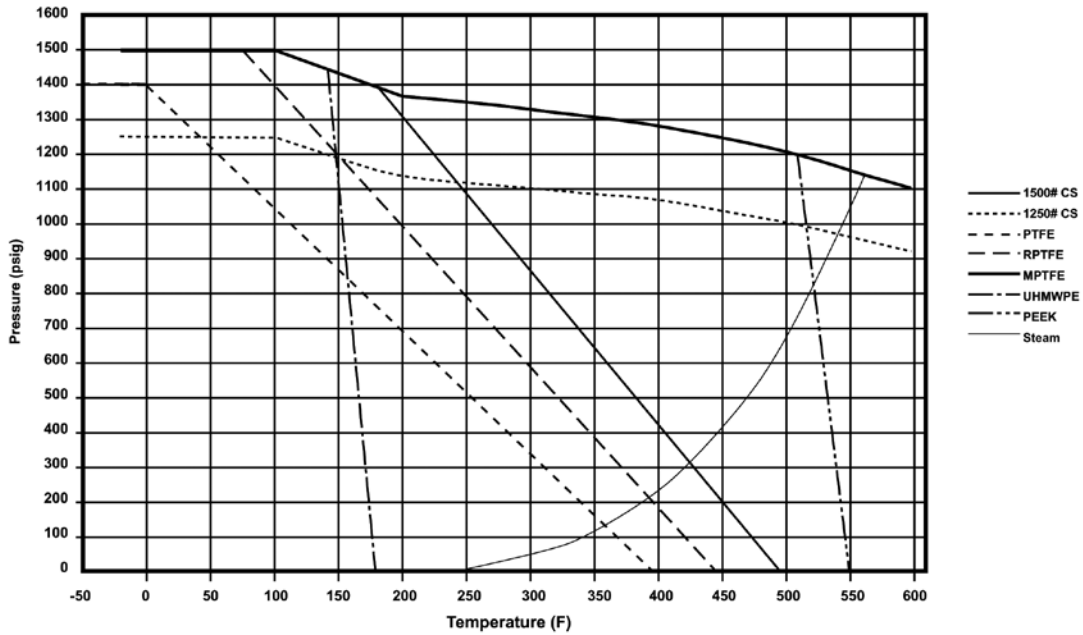

1500# SS (GRAPH 12)

