

Close-Coupled Type R10

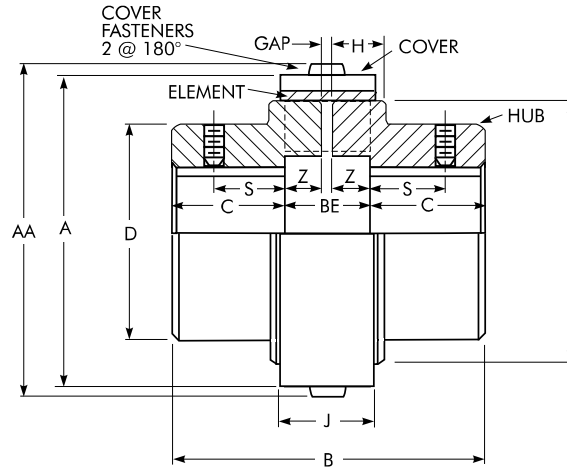

Dimensions (in)

Cplg Size ①	Torque Rating (lb-in)	Allow Speed RPM	Min Bore	Max Bore ②	Cplg Wt (lb) ③		A		AA		B	BE ⑤	C	D	F	H	J	S	Z	GAP ⑤	Cover Fasteners ⑥	
					Nylon Cover	Steel Cover ④	Nylon Cover	Steel Cover ④	Nylon Cover	Steel Cover ④											Size	Allen Wrench
5R	550	4500	0.500	1.625	2.96	3.27	3.01	3.01	3.17	3.17	2.83	0.78	1.02	2.36	2.52	0.59	0.91	0.63	0.35	0.078	M4	M2.5
10R	1,150	4500	0.625	1.875	5.48	5.98	3.56	3.56	3.72	3.72	3.62	0.94	1.34	2.84	2.99	0.75	1.10	0.88	0.43	0.078	M4	M2.5
20R	2,800	4500	0.750	2.375	12.4	13.4	4.96	4.88	5.20	5.12	4.80	1.26	1.77	3.62	4.02	0.98	1.46	1.00	0.59	0.078	M6	M4
30R	4,600	4500	1.000	2.875	20.7	22.1	5.77	5.63	6.01	5.87	5.98	1.42	2.28	4.13	4.65	1.14	1.65	1.25	0.67	0.078	M6	M4
40R	9,100	3600	1.125	3.375	37.6	39.8	7.17	6.97	7.48	7.28	7.13	1.85	2.64	5.12	5.91	1.34	2.15	1.63	0.83	0.197	M8	M5
50R	22,200	3000	1.250	4.125	78.8	82.9	9.09	8.82	9.41	9.13	8.46	2.39	3.03	7.01	7.48	1.81	2.74	1.75	1.10	0.197	M8	M5
60R	35,500	2500	2.000	5.250	—	146	—	10.51	—	10.94	10.84	2.97	3.94	8.25	8.98	2.37	2.64	—	1.39	0.197	M10	M6
70R	70,900	2100	2.750	6.125	—	244	—	12.20	—	12.64	12.76	3.31	4.72	9.88	10.63	2.74	2.95	—	1.56	0.197	M10	M6
80R	133,000	1800	3.375	7.250	—	365	—	14.57	—	15.00	14.84	3.82	5.51	10.63	12.91	3.28	3.35	—	1.79	0.236	M10	M6

- ① Wrapflex is a metric product. Metric to inch conversions may not be direct. Dimensions are for reference only and are subject to change without notice unless certified.
- ② AGMA Class 1 clearance fit bores are standard for Sizes 5R thru 50R, with two setscrews (one over keyway and one at 90°). Interference fit bores and no setscrews are standard for Sizes 60R thru 80R. Long hubs and interference fits are available and recommended when at or near maximum bore and: a) Number of start/stop cycles exceeds 10 per hour; or b) Application service factor = 2.0 or higher.
- ③ Coupling assembly weight is based on "no bore" hubs. For coupling assembly weight and bored hubs, subtract the following value for each hub: $(0.20)(\text{Bore})^2(C)$ lb. Bore in "inches".
- ④ Nylon cover is standard on Sizes 5R thru 50R, with an epoxy-coated steel cover as an option. Epoxy-coated steel cover is standard on Sizes 60R thru 80R, with no option for nylon cover.
- ⑤ "BE" = Standard "Distance Between Shaft Ends" with hubs mounted flush to the shaft ends. "GAP" = Minimum allowable "Distance Between Shaft Ends". Any shaft end spacing between the "GAP" and "BE" dimensions is acceptable. However, if utilizing a shaft end spacing less than the "BE" dimension, the key should not extend beyond the hub face in order to prevent potential interference with the flex element.
- ⑥ Cover fasteners are stainless steel, socket button head cap screws, per ISO 7380-A2. Two cap screws per coupling assembly.