



AVK UNIVERSAL STRAIGHT COUPLING PN 16

601/A
- 043
- 053

The AVK Universal straight couplings PN 16 For cast iron, ductile iron, steel, PVC-U, PVC-M, PVC-O, AC and copper pipes for use on water and sewage applications to max. 40°C.

Product description:
Universal straight couplings

Features:

- Angular deflection of +4 degrees (total 8 degrees)
- 16 bar
- Non tensile resistant

Note: This product provides no longitudinal joint restraint

Standards:

- WRAS Approved materials
- Epoxy coated in line with WIS 4-52-01



601/A - 043 Bolt Long Stainless Steel Barrel



601/A - 053 Bolt Short Stainless Steel Barrel



Tests/Approvals:

- 1.5 X PN

COMPONENT LIST

No.	DESCRIPTION	
1.	End Cap	PVC
2.	Washers	Stainless Steel 316
3.	Nuts	316 Stainless Steel, delta Coated
4.	Bolts	316 Stainless Steel
5.	Bracket	Ductile iron
6.	Rubber seal	EDPM
7.	Barrel	316 Stainless Steel

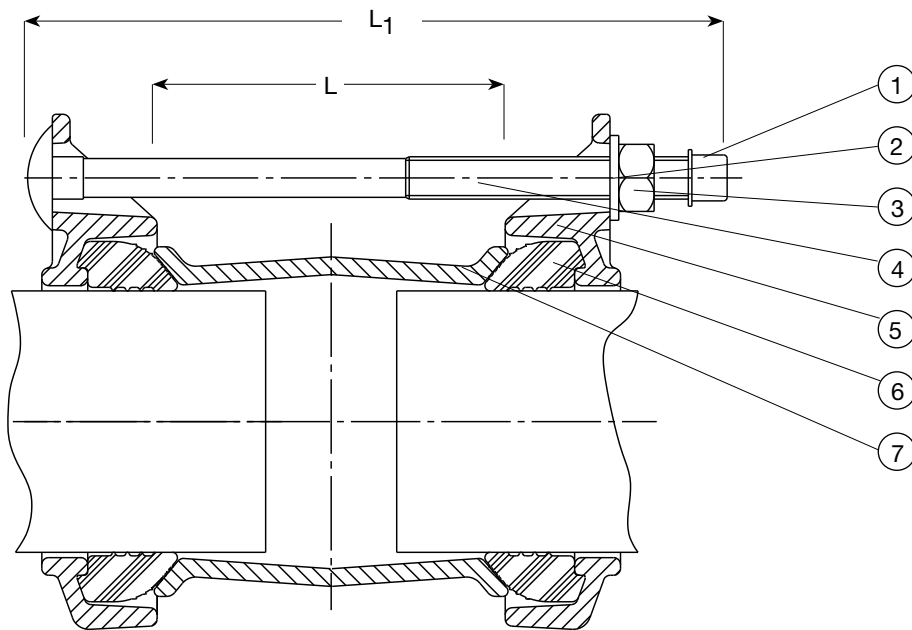

REFERENCE No'S AND DIMENSIONS

AVK Ref No	DN	L mm	L1 mm	Sealing Range mm	Bolts	Theoretical weight kg
601-133-005-4300	100	100	190	109-133	3	5.95
601-183-005-4300	150	115	210	147-183	3	8.45
601-133-004-4300	100	175	270	109-133	3	6.35
601-183-004-4300	150	175	270	147-183	3	8.95

For further details see section "Technical Information".
The designs, materials and specifications shown are subject to change without notice due to the continuous development of our product programme.